

Split skin cryopreserved (viable) large

Product code T0105

Product description

A packet of cryopreserved skin from a deceased multi-tissue donor. The skin is retrieved in strips approximately 60mm wide and 0.3 - 0.5mm thick and packaged in individual packs containing approximately 360cm². The tissue is procured using aseptic procedures by NHS Blood and Transplant (NHSBT) staff in a mortuary or dedicated donation suite. Processed within 24 hours of donation. Processed in-house in licensed pharmaceutical grade cleanrooms (minimum GMP classification C) to reduce microbial load. The skin is washed in isotonic citrate solution to remove blood and treated with an antibiotic cocktail to reduce bioburden. The antibiotic solution contains gentamicin sulphate (4g/l), imipenem (0.2g/l), nystatin (2.5x10⁶ U/l), polymyxin B sulphate (0.2g/l), and vancomycin hydrochloride (0.05g/l), prepared in medium 199 supplemented with 25mM HEPES. The individual strips are sized and cryopreserved in a protectant medium. Aerobic and anaerobic bacterial and fungal cultures are taken and assessed against rejection criteria including pathogenic organisms and gross contaminants. Stored at -135(C and supplied at -79(C. Supplied as individual units according to area required.

Clinical applications

For use primarily in burns surgery.

Benefits - history of safe use

- Supplied by Tissue Services, a specialist function of NHSBT undertaking all aspects of tissue donor evaluation, medical screening, consent, testing, storage, cleanroom processing, quality assurance and supply.
- Donor selection includes medical history/lifestyle check from next of kin and GP and where applicable post mortem report.
- A donor physical examination is carried out at retrieval. The donor is cleared by highly trained clinical staff specialising in tissue donation.
- Pathogen reduction is achieved during processing by treatment with an antibiotic cocktail. Skin quality assessed by highly trained Tissue Services staff.
- Uniform product presentation with minimal variation.
- There are no reported cases of this graft supplied by Tissue Services causing patient harm.

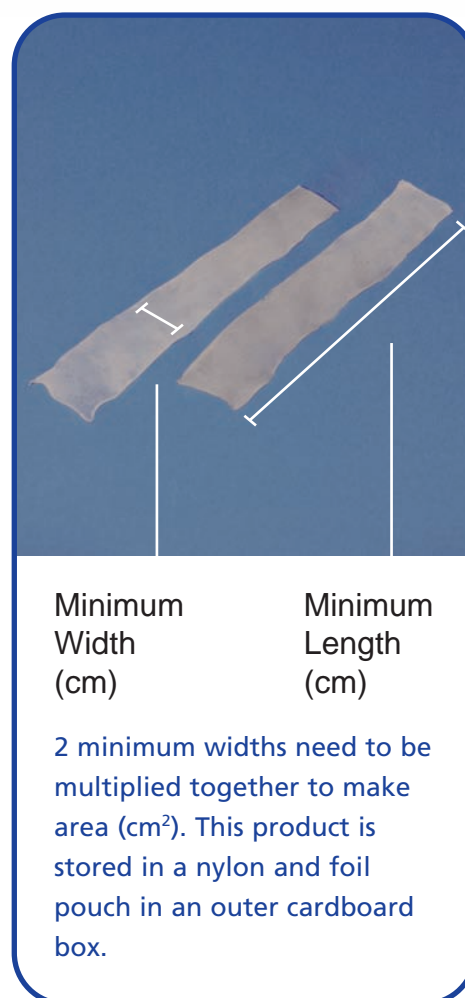

Technical Specification

For further information, clinical or scientific advice or to place an order, please contact your NHSBT tissue bank via the national order line

Tel 0845 607 6820 Fax 0845 607 6819

Quality and Safety

Tissue is sourced from UK donors in compliance with rigorous ethical and clinical standards. The consent process is approved by the Human Tissue Authority. In house experts on tissue donor selection and medical history influence the standard across all donation programmes (blood, tissue and organ). The standard is written by UK blood services in compliance with MSBTO (advisory committee in the Microbiological Safety of Blood, Tissues and Organs). Much of the standard is above and beyond the minimum required by European/UK legislation and regulation. Tissue Services was previously licensed by the MHRA (Medicines and Healthcare product Regulatory Authority) under the UK code of practice now holds establishment licences under the HTA (Human Tissue Authority). The services and facilities including pharmaceutical grade cleanrooms comply with Good Manufacturing Practice. All aspects of the supply chain from education through donor selection, retrieval, processing and supply are managed by Tissue Services staff in house. Processes have been validated in-house by the Tissue Development Laboratory. All microbiology testing is performed in-house by accredited laboratories specialising in donation screening. Final donor assessment and selection is undertaken by in-house clinical specialists in tissue donation. Donations are tracked by barcode including automated test result transfer to the database (the same database used for blood

donation, processing and supply). This database has automated controls to prevent release of non-conforming tissue. Final product release is undertaken as an independent function by specialist NBS Quality Assurance personnel. All activity is regularly reviewed against practice considered best by international standards, with professional links to the British, European and American Tissue Banking Associations.

Labelling and Packaging

The inner pack is a heatsealed nylon pouch (a monomer cast semi-crystalline thermoplastic similar to nylon 6,6), sealed within an outer foil pouch with 15 micron oriented nylon laminated to 50 micron modified polyethylene. This is placed within a cardboard box. The outer pack is labelled with graft type, unique batch number, expiry date, surface area and storage requirements. Batch number, product type, status and expiry date are ISBT 128 barcoded. Enclosed within the box used for transporting the skin is a transplant reporting form with a freepost envelope which can be used for any feedback. If an adverse event or reaction is suspected, telephone the tissue bank immediately.

Delivery

Transport protocols are validated to ensure that grafts arrive with the customer undamaged and in perfect condition. Packaging materials are validated to ensure that the integrity of the graft is maintained up the point of use. Transport containers have been validated to be leak proof and capable of withstanding a dropping regime based on ASTM Standard D4169-01 (Standard Practice for Performance Testing of Shipping Containers and Systems). Delivery is in a disposable transport box containing dry ice (solid carbon dioxide) validated to keep the graft frozen until the time written on the box. It is delivered by either NHSBT Transport or via a courier, usually direct to the point of use e.g. theatre. Next working day delivery is included in the product price. More urgent delivery e.g. same day or by specified time can be arranged at additional cost. Where an operation is graft critical, the patient must not be taken to theatre before the graft has arrived and its condition checked.

Storage

This graft needs to be stored frozen. This product does contain cells therefore if stored beyond 48 hours a storage licence from the HTA is required. For further information please visit www.hta.gov.uk. The graft should be stored at -80°C with a maximum shelf life of 6 months from the date of dispatch or until the expiry date if this is earlier. It cannot be returned to storage at -135°C. The expiry date on the label will be corrected for your storage requirement before dispatch. Freezers need to be designated for clinical use with 24/7 alarms and monitoring. Your blood bank may be able to store this tissue in these conditions. Once thawed, the maximum storage time in a 4°C clinical alarmed and monitored refrigerator is 1 hour.

Alternative products

Frozen Irradiated Skin Allograft.

References:

Title and Authors

Wound Healing. **JN Kearney**

Banking of skin grafts and biological dressings. **JN Kearney**

Guidelines on processing and clinical use of skin allografts.
JN Kearney

Application of a high-level peracetic acid disinfection protocol to re-process antibiotic disinfected skin allografts. **Lomas RJ, Huang Q, Pegg DE, Kearney JN.**

Published In:

Principles and Practice of Burns Management. 1996; pp 187-195. Ed. JAD Settle. Churchill Livingstone.

Principles and Practice of Burns Management. 1996; pp 329-351. Ed. JAD Settle. Churchill Livingstone.

Clin Dermatol. 2005;
23(4):357-64.

Cell Tissue Bank. 2004;
5(1):23-36.

Title and Authors

Banking of non-viable skin allografts using high concentrations of glycerol or propylene glycol. **Huang Q, Pegg DE, Kearney JN.**

The measurement of water activity in allogeneic skin grafts preserved using high concentration glycerol or propylene glycol.

A Ross, JN Kearney

Use of peracetic acid to sterilise human donor skin for production of acellular dermal matrices for clinical use. **Huang Q, Dawson RA, Pegg DE, Kearney JN, MacNeil S**

Assessment of the biological properties of human split skin allografts disinfected with peracetic acid and preserved in glycerol. **Lomas RJ, Cruse-Sawyer JE, Simpson C, Ingham E, Bojar R, Kearney JN.**

Clinical evaluation of skin substitutes. **JN Kearney**

Quality issues in skin banking: a review. **JN Kearney**

An investigation into the potential of extracellular matrix factors for attachment and proliferation of human keratinocytes on skin substitutes. **JT Daniels, JN Kearney, E Ingham**

Effect of burn patient serum on fibroblast and keratinocyte cell morphology. **N Khammo, P McPhie, J A D Settle, E Ingham, J N Kearney**

Skin storage: National Blood Transfusion Centres could take on skin banking and distribution **Myers SR Machesney M, Warwick R & Cussons P**

The effects of variation of cryopreservation protocols on the immunogenicity of allogeneic skin grafts. **E Ingham, JB Matthews, JN Kearney, G Gowland**

The effects of variation of cryopreservation protocols on the immunogenicity of allogeneic skin grafts. **E Ingham, JB Matthews, JN Kearney, G Gowland**

Cryopreservation of cultured skin cells. **JN Kearney**

Novel method of skin substitution in plastic surgery. **J N Kearney**

Novel method of skin substitution in plastic surgery. **J N Kearney**

Fabrication and reorganization of dermal equivalents suitable for skin grafting after major cutaneous injury. **P J Rowling, M J Raxworthy E J Wood, J N Kearney, W J Cunliffe**

Effects of cryobiological variables on the survival of skin using a define murine model. **J N Kearney, L A Wheldon, G Gowland**

Cryopreservation of skin using a murine model: validation of a prognostic viability assay. **J N Kearney, L A Wheldon, G Gowland**

The effect of bacterial products on human fibroblasts and keratinocyte detachment and viability. **D Taylor, C Whatling, J N Kearney, B Matthews, K T Holland**

Collagenase activity during the remodelling of a dermal equivalent. **P J Rowling, M J Raxworthy, J N Kearney**

Published In:

Cell Tissue Bank. 2004; 5(1):3-21.

Cell Tissue Bank. 2004; 5(1):37-44.

Wound Repair Regen. 2004; 12(3):276-87.

Burns. 2003; 29(6):515-25.

Burns. 2001; 27 (5):545-51.

Burns. 1998; 24(4):299-305.

Burns. 1997; 23(1):26-31.

Burns. 1997
May;23(3):212-7.

BMJ. 1996; 313: 439.

Cryobiology. 1993;
30(5):443-58

Cryobiology. 1993; 30(5):443-58.

Burns. 1991; 17(5):380-3.

Burns. 1990; 16: 71.

Burns. 1990; 16: 71.

Biomaterials. 1990; 11(3):181-5.

Cryobiology. 1990; 27(2):164-70.

Cryobiology. 1990; 27(1):24-30.

Br J Dermatol. 1990;
122(1):23-8.

Biochemical Transactions.
1988; 16:326